



OPERATING INSTRUCTIONS

SMART EMS

1. Introduction

The SMART EMS system is used to manage the facility's energy balance. The operation of the system is based on constant control of the flow of energy between the managed installation and the operator's network. The system allows automated reduction of excess electricity produced through intelligent self-consumption, implemented according to modifiable scenarios. Such functionality is part of the My Current priority program for the HEMS/EMS energy management system.

2. Housing mounting

The unit's housing is designed for surface mounting and provides IP65 protection to protect components mounted inside. For installation, you need to open the switchboard, then attach it to the wall by screwing it with screws, using the wall plugs placed in the wall.

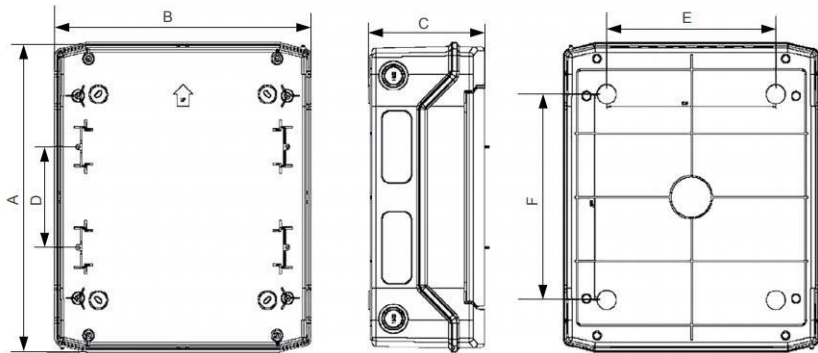

Fig.1 Housing dimensions.

Table 1 Housing dimensions

	A	B	C	D	E	F
24T housing	384mm	319mm	144mm	125mm	210mm	255mm

Table 2 Housing parameters.

Number of rows	2
Housing material	Plastic
Expandability	No
Cover construction	Closed
With a lock	No
Mounting method	Surface mounting
Depth of building in	0
Degree of protection (IP)	65

3. General description of the system

The SMART EMS system consists of a management central unit with safeguards and a two-way electricity meter. The manufacturer recommends the EASTRON SDM72D-M meter which allows communication using the ModBus protocol and RS-485 interface. It is also possible to use other bi-directional meters that implement the communication described above.

The system is supplied in the form of surface-mounted switchgear PST 24T with described cable transitions without an energy meter. The bi-directional electricity meter must be purchased separately or the Smart EMS system must be connected to an existing (cooperating) meter in the installation.

4. Mounting of the system

The SMART EMS system can be mounted anywhere in the electrical system of the facility (building). However, attention should be paid to the overcurrent protection values of the circuits to which the system is connected. The protections preceding the system must not be less than the current drawn by the controlled circuits.

For proper operation of the system, the bi-directional electricity meter should be installed in the building array at the power input from the operator behind the array's main protection. The meter should be connected (communicated) with the SMART EMS system via the RS485 bus. We recommend using a twisted pair cable terminated with 120Ω terminating resistors on both sides for connection. Communication between the meter and the system is carried out using the Modbus RTU protocol. The system requires a three-phase power supply, and the minimum cross-section of the connected wires is 2.5mm².

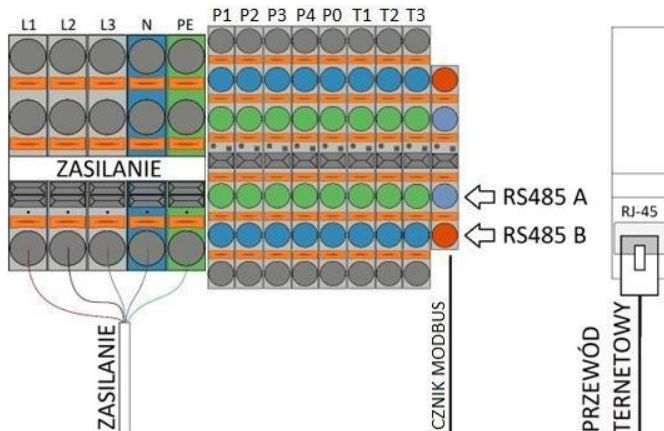

Fig.2 Terminal block of the system power connector.

Zarządzane przez system **SMART EMS** obwody (np. grzałki) należy przyłączyć przy użyciu Circuits (e.g., heaters) managed by the SMART EMS system should be connected using a cable with a minimum cross-section of 2.5mm². It is absolutely forbidden to replace the system's overcurrent protections with protections of higher current value. Such a change may cause damage to the system and will void the warranty. The maximum load current of the outputs must not exceed 16A for circuits P1-P4 and 10A for circuit P0. Circuits P1-P4 are the power circuits for the devices, while P0 acts as a switch.

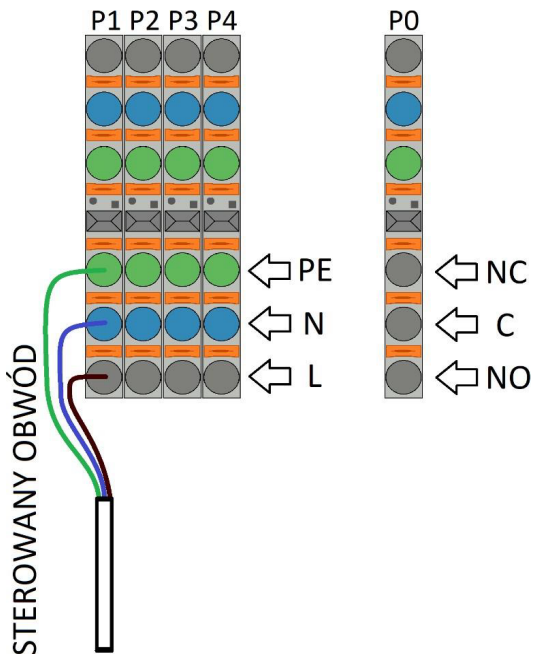

Fig.3 Terminal block of P0-P4 control circuits.

Circuits with higher load current should be connected to the system through additional contactors with the required parameters.

The order of phases included in the bidirectional electricity meter must correspond to the order of phases at the SMART EMS system input. Only such a correlation of the phases will allow the system to operate properly, especially the precise management of energy in each phase.

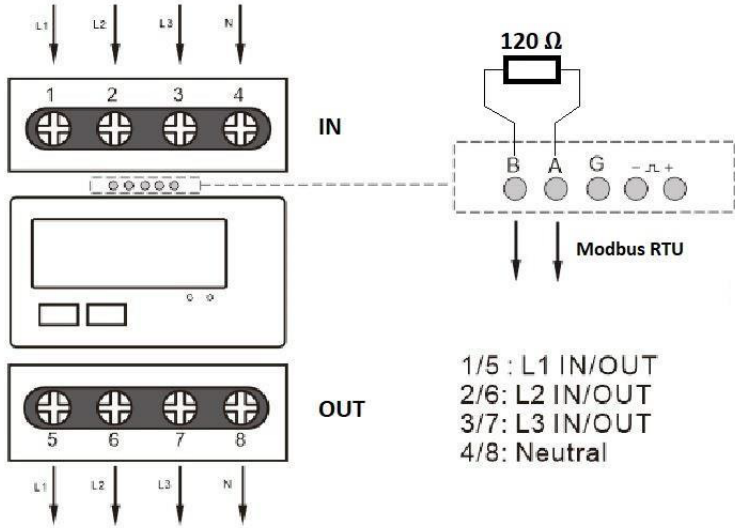

Fig.4 Wiring diagram of bi-directional meter

Connect the 1-Wire temperature sensors and ModBUS to the push-in connectors as indicated.

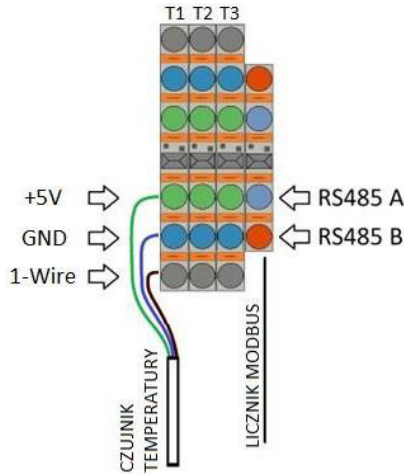

Fig.5 1-Wire and ModBUS connection

5. System configuration

1) Network configuration.

In order to configure the SMART EMS system connect it with an Ethernet cable to the local computer network (switch, router).

The system has a default IP address configured: 192.168.0.100.

To log into the system, enter the following address in your web browser: <http://192.168.0.100>

Default login credentials of the system administrator:

Login: admin Password: admin

First, go to the „Network” tab under „Settings and Management” (1) and update the network settings (2). In the case of automatic address assignment in the LAN, check the „Enable DHCP” option (3). Approving the changes will restart the system. After restarting, log in considering the new settings (IP address). In the case of automatic address assignment, search for the system on the local network using the program LKTools or other tool to search for devices on the network. The LKTools program is available on Keno’s B2B platform.

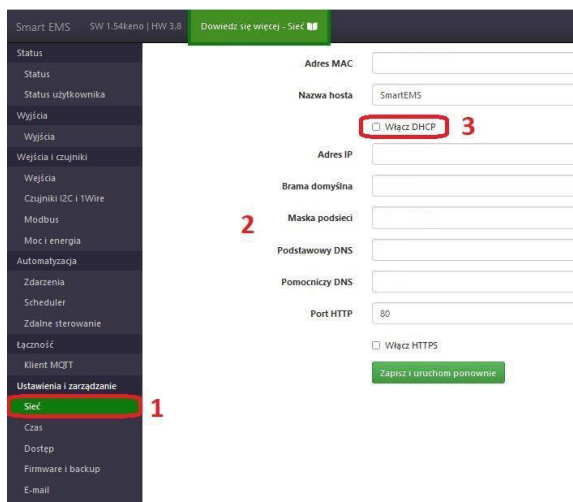

Fig.6 Network configuration.



Fig.7 Searching for the current IP address of a device in LKTools program

Time configuration.

For proper operation of the system, it is necessary to set the current date and time.

All time dependencies perform tasks based on these settings.

To set the current date and time, go to the „Time” tab of the „Settings and Management” section. The time can be set manually or through an NTP server. It is recommended to use the default (set) NTP server. For proper operation of the NTP server, the SMART EMS system must have an Internet connection set up.

2) Configuration of temperature sensors.

Temperature sensors have been configured by the manufacturer in an amount appropriate to the system version. Adding or replacing a sensor requires proper system configuration.

To configure the temperature sensors, go to the „I2C and 1Wire sensors” tab in the „Inputs and sensors” section (1). Once the sensor is properly connected to the connector, read its ID by pressing the „Read ID of connected DS” button (2). To read the ID of the next sensor connected to the system, press the „Read ID of connected DS” button again. Perform this action until the ID of the sensor you want to add to the system is displayed. Then you need to specify at which position the sensor will be added. The selection should be made by entering the appropriate number in the „DS item” field (3). After making a selection, press the „Save ID to position” button. The sensor ID will appear on the selected DS1 - DS8 position (4).

Smart EMS SW 1.54kno | HW 3.8 Dowiedz się więcej - Czujniki I2C i 1Wire

Status
Status
Status użytkownika
Wyjścia
Wyjścia
Wejścia i czujniki
Wejścia
Czujniki I2C i 1Wire
Modbus
Moc i energia
Automatyzacja
Zdarzenia
Scheduler
Zdalne sterowanie
Łączność
Klient MGTT
Ustawienia i zarządzanie
Sieć
Czas
Dostęp
Firmware i backup
E-mail

Czujniki 1Wire

Czujniki DS

ID 28:D2:6C:16:A8:1:3C:BF **2** Odczytaj identyfikator podłączonego czujnika

Pozycja **2** **3** Zapisz identyfikator na pozycji

DS1	28:4:79:CE:40:21:6:99	23.1	Zresetuj identyfikator
DS2	28:D2:6C:16:A8:1:3C:BF 4	29.0	Zresetuj identyfikator
DS3	0:0:0:0:0:0:0	---	Zresetuj identyfikator
DS4	0:0:0:0:0:0:0	---	Zresetuj identyfikator
DS5	0:0:0:0:0:0:0	---	Zresetuj identyfikator
DS6	0:0:0:0:0:0:0	---	Zresetuj identyfikator
DS7	0:0:0:0:0:0:0	---	Zresetuj identyfikator
DS8	0:0:0:0:0:0:0	---	Zresetuj identyfikator
			Zresetuj wszystkie identyfikatory

Fig.8 Configuration of temperature sensors.

Energy meter configuration.

The SMART EMS system has a two-way energy meter EASTRON SDM72D-M configured by default. However, the system installer can configure any two-way energy meter that allows communication via RS-485 interface and Modbus RTU protocol. The manufacturer has also tested and guarantees the correct operation of the CHINT DTSU666 and EASTRON SDM630-Modbus V2 meter. In addition, it is possible to read parameters from a meter connected to the inverter. The system manufacturer has tested and guarantees correct operation of SMART EMS connected with a Fronius Symo GEN24 inverter with a bi-directional energy meter connected.

The configuration of the electricity meter is carried out in the „Modbus” tab in the „Inputs and Sensors” section (1). There are three modules available to the installer (configuration). First, select a predefined meter from the „Module” drop-down list or, to define your own, select the „custom” option (2). Next, enter the address of the meter in the „Slave ID” field (3). The meter address has been defined by the manufacturer and can also be changed by the installer. The default address for EASTRON and CHINT energy meters is „1”. If you select an EASTRON SDM72D-M meter predefined in the system, a table will appear below with the defined meter parameters and the currently read values and units (4). If the „custom” option is selected, manually configure the connected module (counter) by pressing the „Configure custom module” button (5). In order to use the read values of the Modbus registers (measured values from the counter), they must be assigned to the appropriate variables. Do this by pressing the „Configure mapping” button (6).

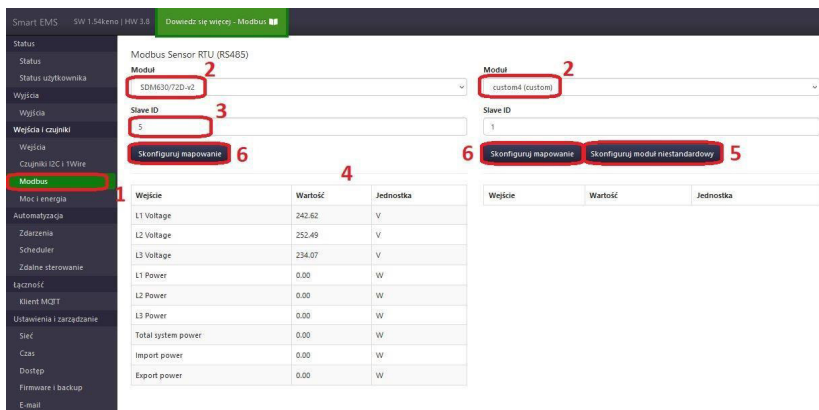

Fig.9 Meter configuration.

After pressing the „Configure mapping” button, a table will appear that allows you to assign a variable to the corresponding parameter read from the counter (1) by selecting from the drop-down list (2). Already assigned variables have an index enclosed in parentheses. The variable names are defined in the system as m1 - m30. To approve the assignment of variables, press the „Save Changes” button.

m1 - m4	- Dostępne w: Moc i energia, Zdarzenia, Klient MQTT, Klient HTTP, OLED, GSM
m5 - m10	- Dostępne w: Zdarzenia, Klient MQTT, Klient HTTP, OLED, GSM
m11 - m30	- Dostępne w: Klient MQTT, Klient HTTP, OLED, GSM

Zmienna	Przypisany odczyt
m1	L1 Voltage (SDM630/72D-v2 - 1, 0)
m2	L2 Voltage (SDM630/72D-v2 - 1, 1)
m3	L3 Voltage (SDM630/72D-v2 - 1, 2)
m4	L1 Power (SDM630/72D-v2 - 1, 7)
m5	L2 Power (SDM630/72D-v2 - 1, 8)
m6	L3 Power (SDM630/72D-v2 - 1, 9)
m7	Total system power (SDM630/72D-v2 - 1, 10)
m8	Import power (SDM630/72D-v2 - 1, 13)
m9	Export power (SDM630/72D-v2 - 1, 14)
m10	Nic
m11	Nic

Fig.10 Parameter mapping.

In order to properly define a different counter („custom” option), it must be further configured. The configuration is done by pressing the „Configure Custom Module” button.

In the window that opens, fill in the name of the module (1), the transmission parameters (Bitrate, Parity bit, Stop bit) (2), the delay between readings of registers counted in seconds (3) and define the readings of the desired registers (4). Further register configurations should be added by pressing the „Add item” button (5). Then enter the appropriate parameters to read the desired value from the register. Register maps with transmission parameters should be obtained from the equipment (meter) manufacturer. The created configuration can be exported to a file (6) for e.g. a quick restoration after a system reset or for use with another customer. The completed configuration should be saved (7) and as in the predefined meter - configure the mapping of variables.

Skonfiguruj modul niestandardowy 5

Nazwa
SDM630 1

Bitrate
9600

Bit parzystości
0 2

Bit stopu
1

Opóźnienie między odczytami rejestrów
0.5 3

Opcje prezentacji				Opcje sprzętowe			
#	Nazwa	Jednostka	Działnik	Adres	Kod funkcji	Rodzaj	
1	L1-N	V	100	0	0x4	float	+
2	L2-N	V	100	2	0x4	float	+
3	L3-N	V	100		0x4	float	+

Dodaj element 5

Zamknij 6 Wyeksportuj konfigurację 7 Importuj konfigurację Zapisz zmiany

Fig.11 Custom module configuration.

3) Output configuration

The outputs of the SMART EMS system have been configured by the manufacturer according to the version. It is recommended only to configure your own output names (1). Defined names are visible in the „Status” and „User Status” tabs (2). However, the outputs have identifiers defined in the system: out0 - out5.

In these tabs, you can test the operation of the outputs by pressing the button under the name of the selected output (3).

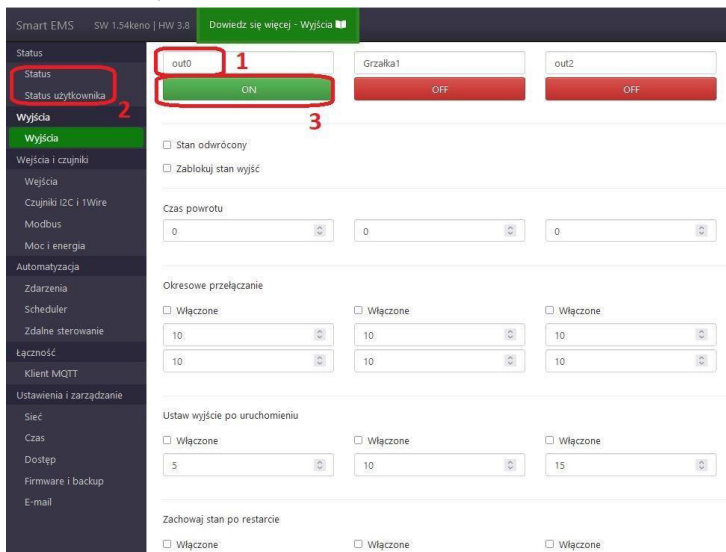

Fig.12 Assignment of names of controlled outputs PO - P4.

4) Device status configuration

In the „Status” tab, you can configure the system parameters visible in the user interface as read from the device. It is possible to customize the range of displayed data by pressing the „Configure item visibility” button (1). The data range set here will be visible to the system user. The SMART EMS system has a manufacturer-configured range of presented data depending on the version of the device.

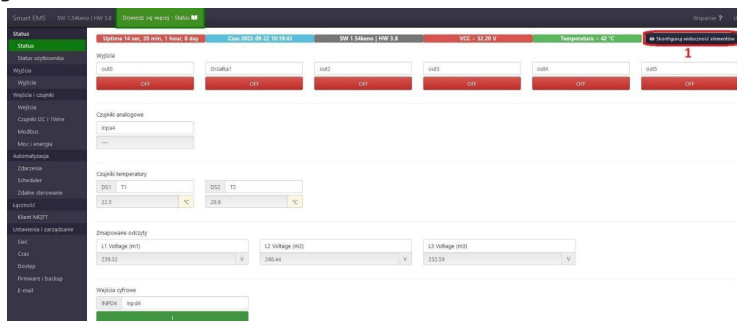

Fig.13 Personalize the displayed data.

5) User status configuration

In the „User Status” tab (1) it is possible to configure the GUI view of the system for a regular user. The SMART EMS system has a configured interface depending on the version of the device. Modification of the interface is possible only after it is unlocked by the installer. This action is performed by pressing the „Unlock System” button (2). After unlocking the layout, the name of the button will change to „Lock Layout” and you can freely arrange the presented system elements. The range of data that can be presented can be specified by the installer in the „Status” tab. After editing the interface, save it (3) and lock it (2).

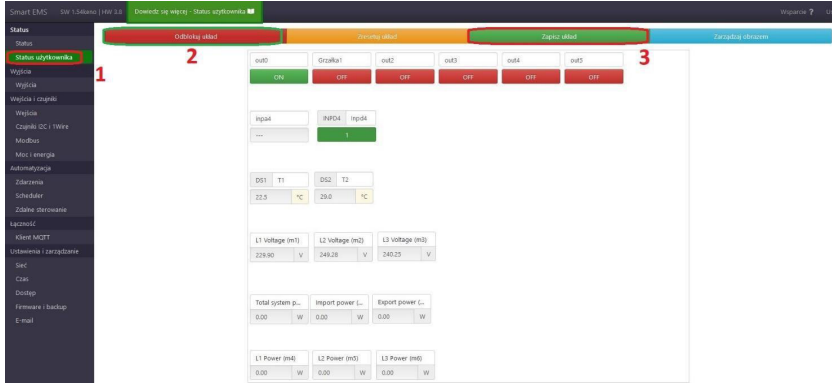

Fig.14 Edit user status layout.

6) Configuration of logical functions

The essence of SMART EMS (energy management system) is the automated response to exceeding preset thresholds of exported electricity to the operator’s grid. System response scenarios should be implemented in the „Events” tab in the „Automation” section (1). The system allows you to set the appropriate response of an output selected from the „Action” list (2) to a preset input parameter selected from the „Source” drop-down list (3). It is also possible to combine input conditions using AND, OR, XOR, NOR, NAND logical operators (4).

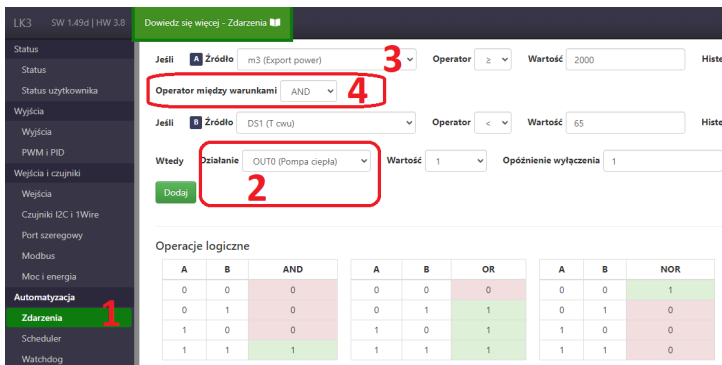

Fig.15 Configuration of events.

After pressing the add button, the set action scenario will be added to the list (5). To run the scenario, check the „On” box (6). If you check „Per” option (7), you will not be able to manually control the outputs. In this case, any manual change in the state of the output selected in the „Action” field will have a lower priority than the running scenario. A detailed description of the possible functions is displayed by pressing the „Learn more - events” button.

Lista zdarzeń **5**

#	Źródło	Operator	Wartość	Stan	Operator między warunkami	Działanie	Opóźnienie wyłączenia	
1	m4 (L1 - N)	≥	330 ±0	No	-	EVENT2 → 1	0	<input type="checkbox"/> On <input type="checkbox"/> Per <input type="button" value="Info"/> <input type="button" value="Delete"/>
2	m3 (Export power)	≥	2000 ±100	No	AND	OUT0 (Pompa ciepła) → 1	1	<input checked="" type="checkbox"/> On <input checked="" type="checkbox"/> Per <input type="button" value="Info"/> <input type="button" value="Delete"/>
	D51 (T cwu)	<	65 ±3	Yes				6 7

Fig.16 Event Configuration.

In the example shown, a scenario was created to start Heater 1 at the OUT1 output - if two conditions (8) are met together:

- instantaneous power returned to the operator’s network will exceed 2kW with a hysteresis of 100W,
- the temperature in the domestic hot water tank will be lower than 65°C with a hysteresis of 3°C. The scenario shutdown will be delayed with a time constant of 60 sec.

The scenario is enabled by checking the „On” option and is permanent by checking the „Per” option.

In the same way, you can create scenarios for other heaters or other devices connected to the system. This is also the way to turn on or off devices, e.g. to support the connector (switch) OUT0 (heat pump, car charger, air conditioner, etc.). The system provides the ability to set the states of the virtual outputs EVENT1-EVENT8, for example, in order to apply more elaborate logical relationships between inputs (sources).

When creating relationships related to voltage and/or energy management on individual phases (e.g., turning on the load on the phase on which the voltage limit is exceeded), check the appropriate connection of the bi-directional meter and the system. The order of phases connected to the energy meter must be analogous to the order of phases in the Smart EMS system.

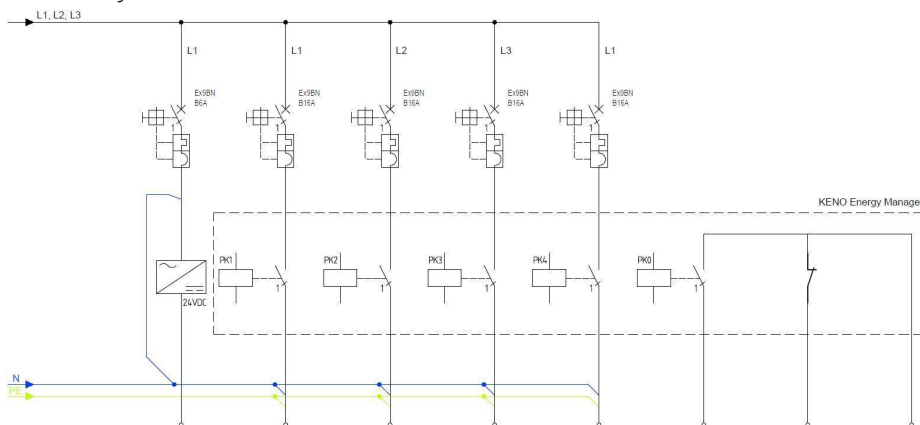

Rys.17 Podział odbiorów sterowanych na poszczególne fazy.

7) MQTT Client Configuration

In order to implement data presentation and possible remote output serialization, the Smart EMS system enables data exchange with an MQTT server.

In order to exchange data, you need to create an account on the <http://mqtt.ats.pl>. The procedure for setting up an account is described in section 6 of this manual. Configuration of the MQTT client can be found in the „MQTT Client” tab in the „Connectivity” section (1). Then check the options „Enable MQTT” (2) and „Enable authentication (login/password)” (3).

Proper connection to the MQTT server requires completion of the form (4).

In the „Password” field enter password from the „MQTT client details” section in the settings of the account created on <http://mqtt.ats.pl>. Then select the appropriate data to be sent to the MQTT server (5). To complete the communication, save the created configuration by pressing the „Save” button (6).

The screenshot shows the 'Klient MQTT' configuration page. The left sidebar has 'Klient MQTT' highlighted (1). The main area has 'Włącz MQTT' checked (2) and 'Włącz uwierzytelnianie (login/hasło)' checked (3). The form fields are: 'Adres serwera' (mqtt.ats.pl), 'Port' (1883), 'Login' (login), and 'Hasło' (password) (4). The 'Wyślij dane' section has several checkboxes for data types like 'WYCENY', 'TEMP', 'DIFFY ERROR ERROR', etc. (5). The 'Zapisz' button is at the bottom (6).

Fig.18 MQTT client connectivity settings.

6. MQTT server configuration

In order to present data from the SMART EMS system in the mobile application and on the MQTT server, you need to create an account on the portal <http://mqtt.ats.pl>.

After creating an account in the „Devices” menu (1), add a new device by pressing „+Add device” (2) and by filling out the form (3). To approve the changes, press the button below the form (4).

The screenshot shows the 'Urządzenia' page on the portal. The 'Urządzenia' menu item is highlighted (1). The '+ Dodaj urządzenie' button is highlighted (2). The form for adding a new device is highlighted with a red box (3), showing 'Nazwa' as 'LK_KENIO_1' and 'Typ' as 'LK3'. The '+ Dodaj urządzenie' button at the bottom of the form is highlighted (4).

Fig.19 Adding new devices on the portal.

The device added to the portal will appear in the list. It will also be automatically assigned a topic prefix (1). Enter the prefix in the appropriate place on the system configuration form (cf. section 5, item 9).

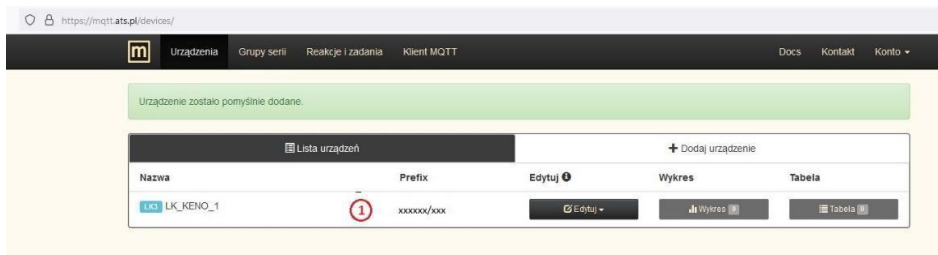

Fig.20 List of devices on the MQTT platform.

In order to configure the displayed data on the <http://mqtt.ats.pl> portal press the „Edit” button and select „Series Settings” from the drop-down list. In the new window that opens, select (1) which data from the SMART EMS system are to be presented on the portal. The names of the output inputs are marked as subjects with prefix (2). Regardless of the names of individual inputs/outputs specified in the SMART EMS system portal allows you to give your own names to individual topics (3). You can also choose the appropriate color to represent the data on the chart (4). To approve the changes to the lies, press the „Save Series Settings” button below the table at the bottom of the page.

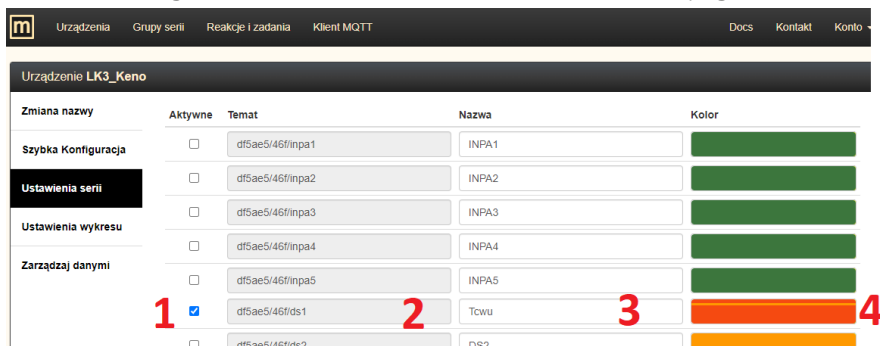

Fig.21 Configuration of displayed data.

For proper SMART EMS system login to the portal, you need to read the password necessary to enter in the system settings. To do this, from the „Account” drop-down list select (1) option „Account settings” (2) and read the passwords assigned on the portal (3). This password is not the same as the login password for the <http://mqtt.ats.pl> portal.

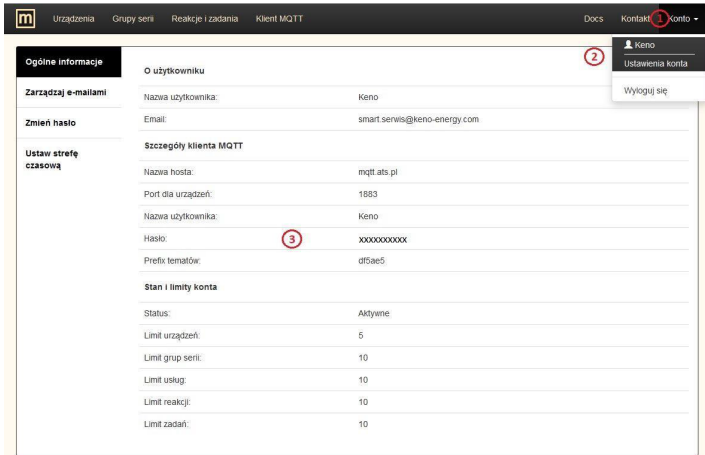

Fig.22 Reading the assigned password.

After performing the basic configuration described above, it will be possible to present the data on a chart in the <http://mqtt.ats.pl> portal. In the „Devices” menu, press the „Chart” button, after which a window opens with all the parameters (topics) selected for display.

The chart can be reduced to less data by clicking the mouse on their symbols (1). Data represented by a crossed-out symbol will not be displayed in the chart. The time range of the presented values can be adjusted with the slider (2). It is also possible to download the chart to a local drive. To do this, from the „Actions” menu (3) select the „Export data as PNG” options. You can also change the range of data presented to predefined values (4) and change the chart settings in terms of labels and Y-axis limits (5).

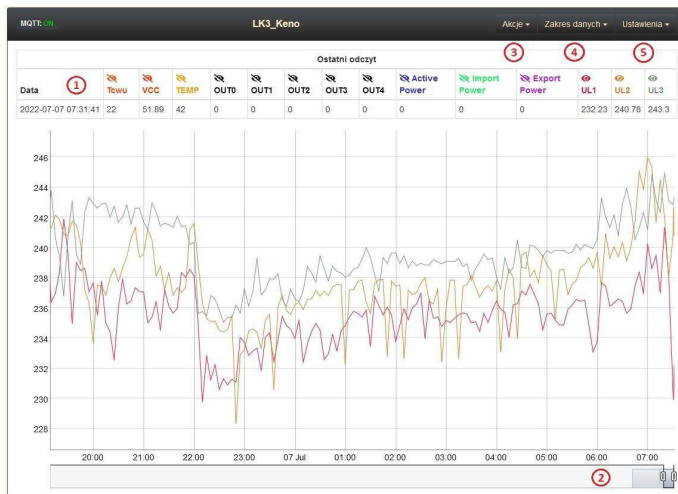

Fig.23 Presentation of data in a graph.

The portal allows much broader use than the basic settings described in this manual. Full information on the portal's capabilities can be found on the help page available by selecting „Docs” option from the portal's main menu.

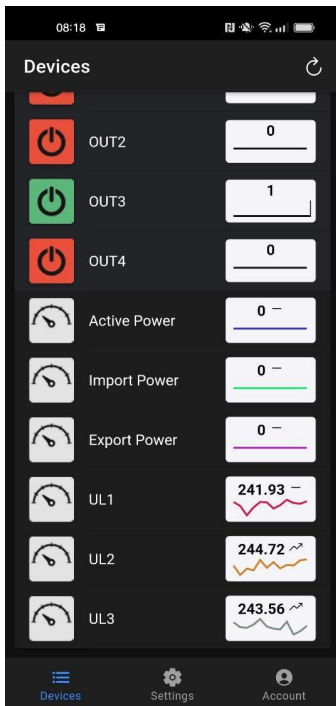

Fig.24 ATS MQTT mobile application.



v 1.1
05.23