

Technical Note – Retrofit Application, SigenStors Integrated with Installed Inverters

Revision History

Version 1.0, March 2024 – Initial release

Version 2.0, April 2024 – Second release: Added Zero export function instruction

Background

For existing on-grid solar PV projects that are already in operation (using inverters from other brands), it is hoped that by adding a battery energy storage system (BESS), the entire installation can achieve maximum self-consumption, while keeping a centralized monitoring, management, and zero-injection requirements between the newly added BESS and the existing on-grid solar system. The retrofit solution proposed via SigenStors provided by Sigenergy can meet the requirements in this scenario.

Introduction of the existing on-grid system

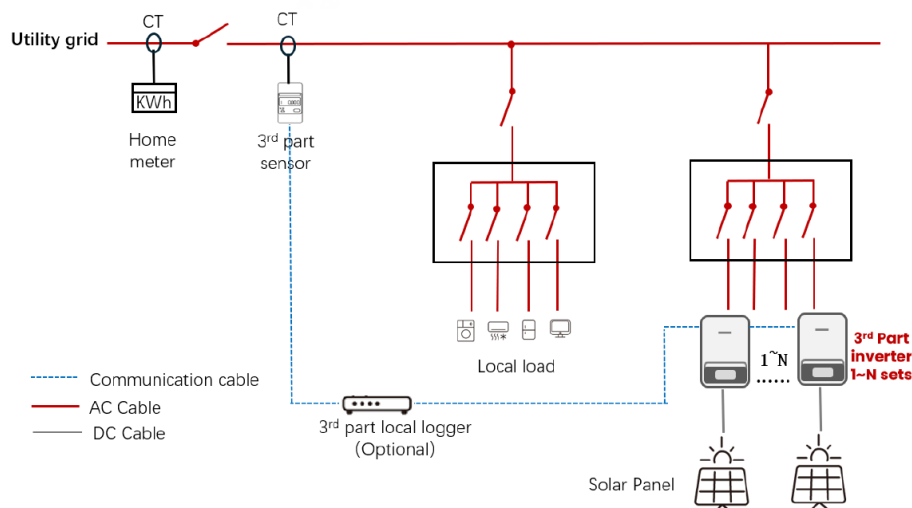

Figure 1: Single line diagram of the existing on-grid system

The existing on-grid system description:

1. Pure on-grid scenario, power outage scenario will not occur (There is no backup).
2. One or several 3rd-party PV on-grid inverters have been installed.
3. No existing battery system.
4. A CT or power sensor has been installed to meet zero-injection requirement: the inverter(s) communicates with the power sensor (or through a local logger) to detect the power at the grid connection point in real time. When the inverter detects power injection into the grid at the power sensor point, it will limit its AC output power to ensure that the solar system has no power injection into the grid.
5. The existing inverters system is unable to communicate with a potential newly solar and ESS system.

Requirements for retrofit:

1. By adding a Sigenergy battery system (DC or AC coupled), the new system can support centralized management, maximum consumption, and zero injection requirements.
2. The excess solar power from existing PV inverters be captured by the newly added batteries.
3. When the solar power of existing inverters is insufficient, Sigenergy energy storage system supplements power to the load.
4. Support monitoring of the newly added system information and existing inverters system information at the same time (optional).

! Sigenergy retrofit solution

In response to the existing system and retrofit requirements, Sigenergy can provide the solution with all-in-one Sigenstor and two power sensors, which can achieve the retrofit requirements mentioned above without communicating with existing 3rd-party inverters.

The single line diagram of the retrofit solution is shown below:

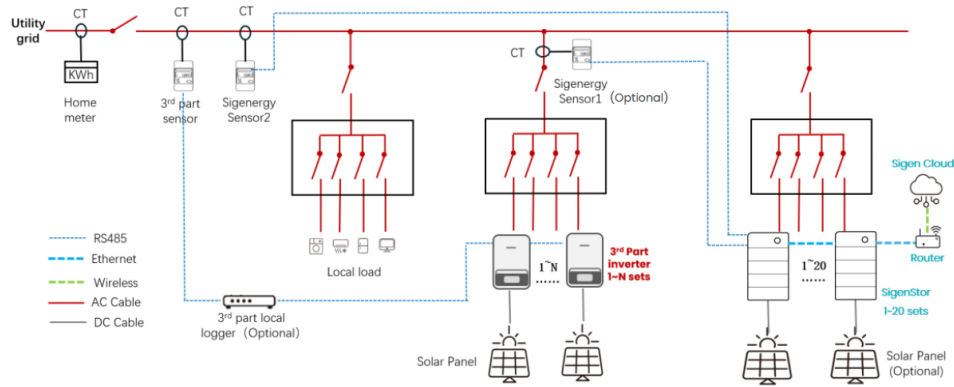
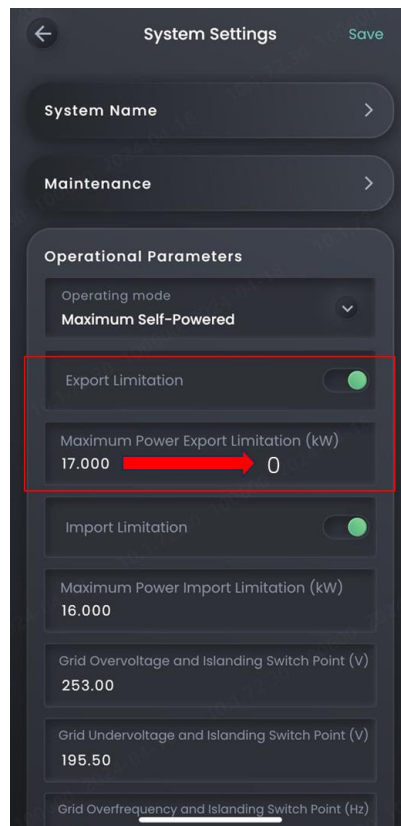

Figure 2: Single line diagram of the retrofit solution

- **Sigenergy Sensor 1** is optional. It is used to get the power generation data (such as AC active power, AC current, voltage, and yield) of the existing solar system and display it on the mySigen APP. If there is no need to show the existing system information on mySigen APP, then there is no need to add this sensor.
- **Sigenergy Sensor 2** is mainly used for power control at the grid connection point, to realize the maximum consumption and zero-injection functions for the entire system. To achieve zero injection functions, please refer to the image below which indicates the two steps to enable zero injection functions from mySigen APP.



Step 1: Enable the Export Limitation

Step 2: Set Maximum Export Limitation to "0"

Control strategy for maximum consumption and zero-injection

1. **When the output power of the 3rd-party inverters is less than the Local Load power:** the newly added SigenStors will supplement the power supply to the load. When both the newly added SigenStor and the 3rd-party inverters cannot support the load, the remaining power supply demand is supplemented by importing power from the utility grid.
2. **When the power of the 3rd-party inverters exceeds the load power:** the newly added SigenStor will detect the injection current at the point of **Sigenergy Sensor 2** and control the SigenStor to charge the battery to ensure zero injection at the point of **Sigenergy sensor 2**. In this way, the excess power of the 3rd-party inverter will charge Sienergy's battery and will not be wasted.
3. **When the output power of the 3rd-party inverters is larger than the load power, and the remaining power is larger than the chargeable power of the newly added SigenStors:** the SigenStors will charge the battery at its maximum chargeable power. Meanwhile, 3rd-party inverters can detect the injection current at the point of the 3rd party sensor and limit their output power to ensure zero-injection at the point of the 3rd party sensor.

Important Note:

From the above control strategy, Sienergy's SigenStors will prioritize controlling zero-injection at the point of **Sigenergy Sensor 2**, and then the 3rd-party inverters will control zero-injection at the point of 3rd party sensor. To keep a stable control, the zero-injection parameter at the point of **Sigenergy Sensor 2** is generally set to be slightly **smaller** than that at the point of 3rd party sensor. In this way, SigenStors will prioritize the implementation of the zero-injection strategy. If it exceeds the control range of SigenStors, the 3rd-party inverters will do the zero-injection function and limit its output power.

- For example: Setting the zero-injection parameter of the 3rd-party sensor to 0W, and setting that of the **Sigenergy Sensor2** to (-100)W. In this way, the SigenStors system will constantly control the power at the point of **Sigenergy Sensor2** $\leq (-100)W$, and the 3rd-party inverters will control the power at the point of 3rd party sensor $\leq 0W$, ensuring that the SigenStors prioritizes zero-injection control.

3rd-party inverter monitoring (optional)

When customers need to display 3rd-party inverters system information on the mySigen APP, they can add an Sigenergy sensor at the AC output of the existing inverters. (As shown in **Sigenergy Sensor1** in the **Figure2**).

*If there is no such requirement, this meter is not required.

Important Note:

Sigenergy Sensor 1 in the **Figure 2** can only be connected to the RS485-1 port of

the SigenStor (15, 16 Pin shown as below). **Sigenergy Sensor 2** in the figure 2 can only be connected to the RS485-2 port of the SigenStor (13, 14 Pin shown as below). The order of the two ports cannot be exchanged.

5.4.1 Introduction to Correspondence

COM terminal of the inverter

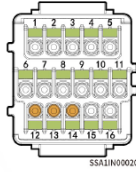

Tips

The appearance and specific wiring of the power sensor can be found in the instruction manual delivered with the case.

Description	Interface definition	COM terminal of the inverter	Sigen Sensor TP-DH (SDM630MODBUS V2)	Sigen Sensor TP-CT120-DH (SDM630 MCT 40mA/120A)	Sigen Sensor TP-CT300-DH (SDM630MCT 40mA/300A)	Sigen Sensor TP-CT600-DH (SDM630MCT V2/600A)
(Reserved) DO1, connected to third party intelligent electric equipment, such as switch control and heat pump	Dry contact 1 - Common	1	-	-	-	-
	Dry contact 1 - NO	2	-	-	-	-
(Reserved) DO2, connected to third party intelligent electric equipment, such as switch control and heat pump	Dry contact 2 - Common	3	-	-	-	-
	Dry contact 2 - NO	4	-	-	-	-
(Reserved) For power scheduling, such as DRM and Ripple control	DI1, digital input 1	5	-	-	-	-
	DI2, digital input 2	6	-	-	-	-
	DI3, digital input 3	7	-	-	-	-
	DI4, digital input 4	8	-	-	-	-
	DI5, digital input 5	9	-	-	-	-
	Signal GND	10	-	-	-	-
COM port used to access the power sensor	PE signal shielding ground	12	-	-	-	-
	RS485 signal 2, B-	13	B-	13	13	13
	RS485 signal 2, A+	14	A+	14	14	14
(Reserved) Standby RS485 port	PE signal shielding ground	11	-	-	-	-
	RS485 signal 1, A+	15	-	-	-	-
	RS485 signal 1, B-	16	-	-	-	-

Figure 3: Inverter RS485 Wiring Diagram

Adding an existing third-party installed inverter in the mySigen APP:

Please log in with an end-user account:

1. Select "Add System Device"
2. Select "Inverter"
3. Fill the brand and model of the installed inverters
4. Select the power sensor model
5. Finish adding installed inverters

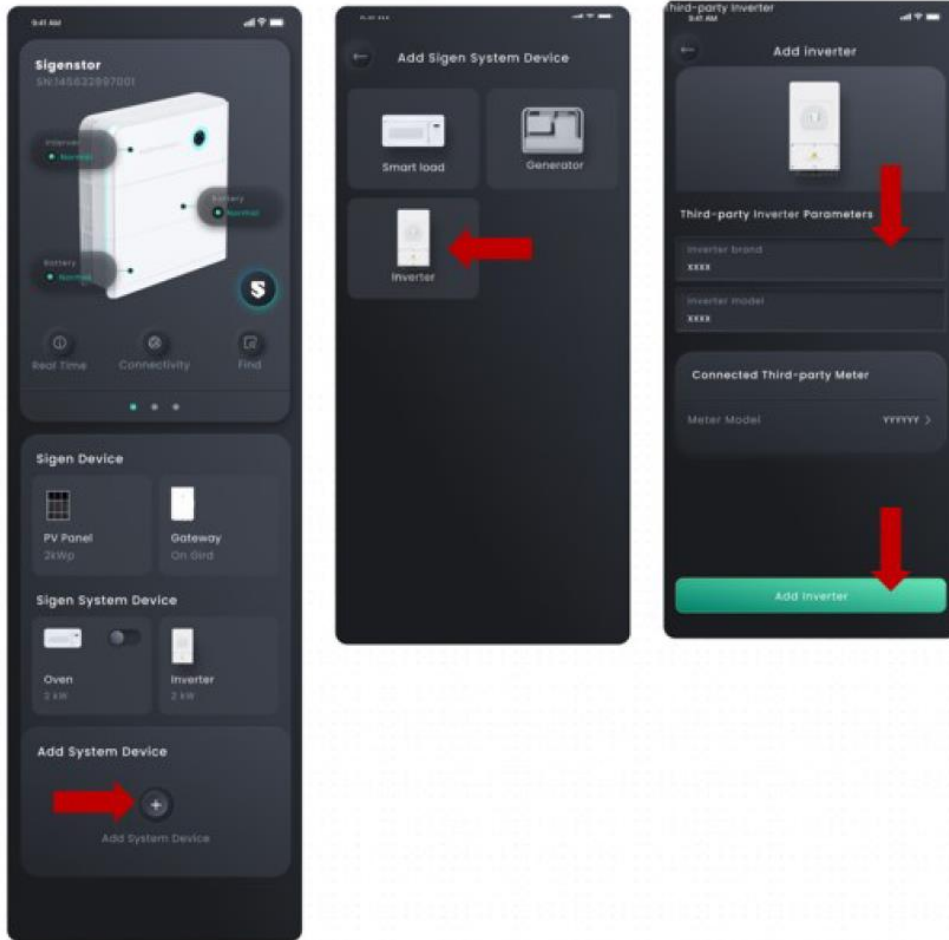

Figure 4: Interface of adding 3rd party inverter system

Query the 3rd-party inverters system information on the mySigen App:

After adding the existing inverter, you can query the following 3rd-party inverter system information on the mySigen App:

1. Real-time information of installed inverters, including voltage, current, active power, and energy.
2. The installed inverters can be displayed on the homepage with energy and power.

*Additional display information will be added in the next version of the mySigen APP

Backup retrofit solution

If the newly added system also needs backup capabilities where it is required to supply power when a power outage occurs, Sigenenergy can provide a solution for this scenario through its Sigen Gateway in combination with the SigenStor solution.

